

# B54 Channel & Combinations

## B54

- Thickness: 14 Gauge (1.9 mm)
- Standard lengths: 10' (3.05 m) & 20' (6.09 m)
- Standard finishes: Plain, Dura-Green, Pre-Galvanized, Hot-Dipped Galvanized, Stainless Steel Type 304 or 316, Aluminum
- Weight: .97 Lbs./Ft. (1.44 kg/m)

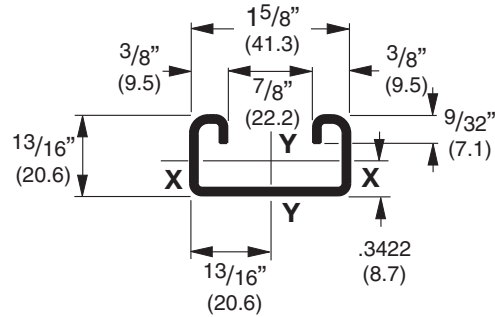
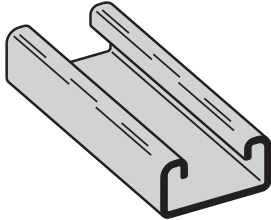

### SECTION PROPERTIES

Channel	Weight		Areas of Section		Moment of Inertia (I)		Section Modulus (S)		Radius of Gyration (r)		Moment of Inertia (I)		Section Modulus (S)		Radius of Gyration (r)	
	lbs./ft.	kg/m	sq. in.	cm <sup>2</sup>	in. <sup>4</sup>	cm <sup>4</sup>	in. <sup>3</sup>	cm <sup>3</sup>	in.	cm	in. <sup>4</sup>	cm <sup>4</sup>	in. <sup>3</sup>	cm <sup>3</sup>	in.	cm
<b>B54</b>	1.016	(1.51)	.299	(1.93)	.0263	(1.09)	.0560	(.92)	.297	(.75)	.1106	(4.60)	.1361	(2.23)	.608	(1.55)
<b>B54A</b>	2.032	(3.02)	.598	(3.86)	.1226	(5.10)	.1510	(2.47)	.453	(1.15)	.2212	(9.12)	.2722	(4.46)	.608	(1.55)

Calculations of section properties are based on metal thicknesses as determined by the AISI Cold-Formed Steel Design Manual.

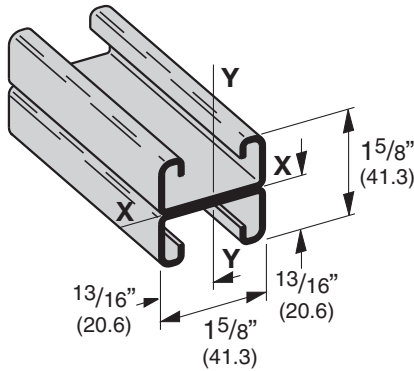

### B54A

Wt. 1.94 Lbs./Ft. (2.89 kg/m)

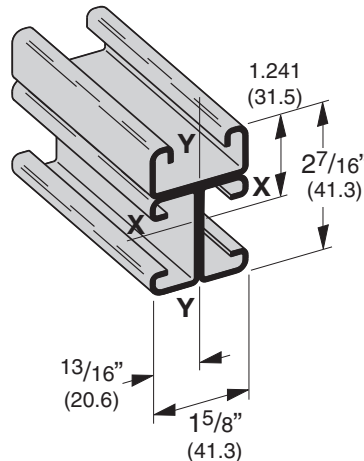

### B54B3

Wt. 2.91 Lbs./Ft. (4.33 kg/m)

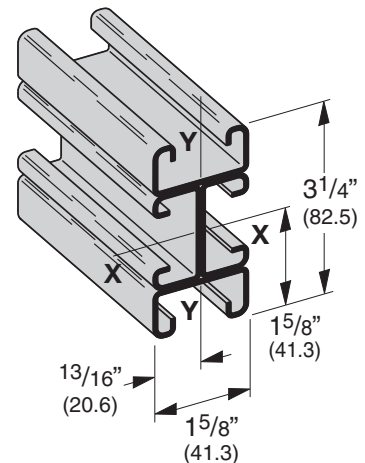

### B54B4

Wt. 3.88 Lbs./Ft. (5.77 kg/m)

Reference page 14 for general fitting and standard finish specifications.

# B54 Beam & Column Loading Data

## BEAM LOADING

Beam Span In. mm		Channel Style	Uniform Load and Deflection				Uniform Load @ Deflection =			
			Lbs. N		In. mm		1/240 Span		1/360 Span	
			Lbs.	N	In.	mm	Lbs.	N	Lbs.	N
12	(305)	<b>B54</b>	870	(3870)	.027	(.68)	870	(3870)	870	(3870)
		<b>B54A</b>	870*	(3870)	.005	(.13)	870*	(3870)	870*	(3870)
24	(609)	<b>B54</b>	465	(2068)	.108	(2.74)	430	(1913)	287	(1276)
		<b>B54A</b>	870*	(3870)	.043	(1.09)	870*	(3870)	870*	(3870)
36	(914)	<b>B54</b>	310	(1379)	.243	(6.17)	191	(849)	127	(565)
		<b>B54A</b>	832	(3701)	.141	(3.58)	832	(3701)	591	(2629)
48	(1219)	<b>B54</b>	233	(1036)	.432	(10.97)	108	(480)	72	(320)
		<b>B54A</b>	624	(2775)	.250	(6.35)	499	(2219)	332	(1477)
60	(1524)	<b>B54</b>	186	(827)	.676	(17.17)	69	(307)	46	(204)
		<b>B54A</b>	499	(2219)	.391	(9.93)	319	(1419)	213	(947)
72	(1829)	<b>B54</b>	155	(689)	.973	(24.71)	48	(213)	32	(142)
		<b>B54A</b>	416	(1850)	.563	(14.30)	222	(987)	148	(658)
84	(2133)	<b>B54</b>	133	(591)	1.324	(33.63)	35	(155)	23	(102)
		<b>B54A</b>	357	(1588)	.766	(19.45)	163	(725)	109	(485)
96	(2438)	<b>B54</b>	116	(516)	1.730	(43.94)	27	(120)	18	(80)
		<b>B54A</b>	312	(1388)	1.001	(25.42)	125	(556)	83	(369)
108	(2743)	<b>B54</b>	103	(458)	2.189	(55.60)	21	(93)	14	(62)
		<b>B54A</b>	277	(1232)	1.267	(32.18)	98	(436)	66	(293)
120	(3048)	<b>B54</b>	93	(413)	2.703	(68.65)	17	(75)	11	(49)
		<b>B54A</b>	250	(1112)	1.564	(39.72)	80	(356)	53	(236)

Based on simple beam condition using an allowable design stress of 25,000 psi (172 MPa) in accordance with MFMA, with adequate lateral bracing (see page 11 for further explanation). Actual yield point of cold rolled steel is 42,000 psi. To determine concentrated load capacity at mid span, multiply uniform load by 0.5 and corresponding deflection by 0.8. \*Failure determined by weld shear.

## COLUMN LOADING

Unbraced Height In. mm		Channel Style	Max. Column Loading K = .80				Max. Column Loading (Loaded @ C.G.)					
			Loaded@ C.G.		Loaded@ Slot Face		K = .65		K = 1.0		K = 1.2	
			Lbs.	N	Lbs.	N	Lbs.	N	Lbs.	N	Lbs.	N
12	(305)	<b>B54</b>	6186	(27516)	2586	(11503)	6284	(27952)	6032	(26831)	5857	(26053)
		<b>B54A</b>	12763	(56772)	4060	(18060)	12835	(57093)	12645	(56248)	12501	(55607)
24	(609)	<b>B54</b>	5464	(24305)	2254	(10026)	5763	(25635)	4968	(22099)	4300	(19127)
		<b>B54A</b>	12135	(53979)	3857	(17157)	12420	(55247)	11663	(51879)	11087	(49317)
36	(914)	<b>B54</b>	4300	(19127)	1816	(8078)	5043	(22432)	3076	(13683)	2136	(9501)
		<b>B54A</b>	11087	(49317)	3549	(15787)	11728	(52169)	10026	(44598)	8729	(38828)
48	(1219)	<b>B54</b>	2703	(12023)	1341	(5965)	3920	(17437)	1730	(7695)	1201	(5342)
		<b>B54A</b>	9620	(42792)	3169	(14096)	10759	(47858)	7734	(34402)	5571	(24781)
60	(1524)	<b>B54</b>	1730	(7695)	995	(4426)	2621	(11659)	1107**	(4924)	769**	(3420)
		<b>B54A</b>	7734	(34402)	2745	(12210)	9514	(42320)	5134	(22837)	3566	(15862)
72	(1829)	<b>B54</b>	1201	(5342)	763	(3394)	1820	(8096)	769**	(3420)	534**	(2375)
		<b>B54A</b>	5571	(24781)	2291	(10191)	7992	(35550)	3566	(15862)	2476	(11014)
84	(2133)	<b>B54</b>	883**	(3928)	603	(2682)	1337	(5947)	565**	(2513)	-	-
		<b>B54A</b>	4093	(18206)	1913	(8509)	6200	(27579)	2620	(11654)	1819**	(8091)
96	(2438)	<b>B54</b>	676**	(3007)	487	(2166)	1024**	(4555)	-	-	-	-
		<b>B54A</b>	3134	(13941)	1616	(7188)	4747	(21116)	2006**	(8923)	1393**	(6196)
108	(2743)	<b>B54</b>	534**	(2375)	401	(1784)	809**	(3598)	-	-	-	-
		<b>B54A</b>	2476	(11014)	1380	(6138)	3751	(16685)	1585**	(7050)	1100**	(4893)
120	(3048)	<b>B54</b>	-	-	336	(1494)	655**	(2913)	-	-	-	-
		<b>B54A</b>	2006**	(8923)	1190	(5293)	3038	(13513)	1284**	(5711)	-	-

\*\*Where the slenderness ratio  $\frac{KL}{r}$  exceeds 200, and K = end fixity factor, L = actual length and r = radius of gyration.

Reference page 14 for general fitting and standard finish specifications.