

Grip Strut Plank - Safe Loading Tables

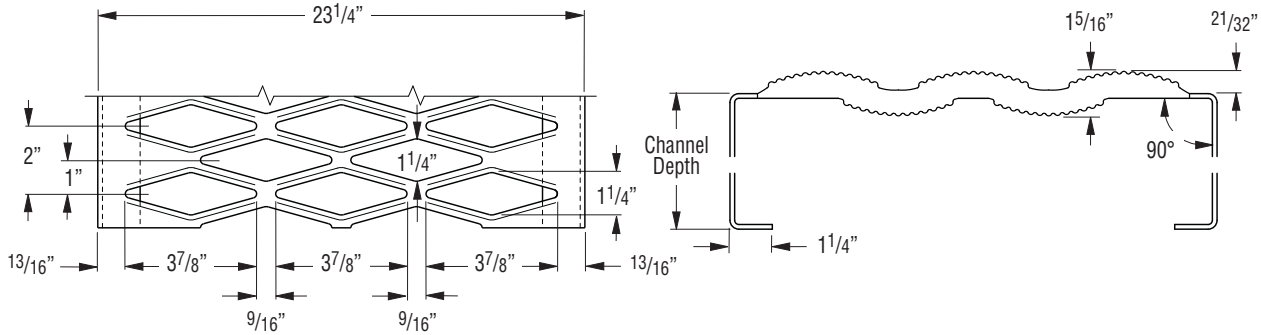

5-Diamond Plank — 23 1/4" Width — "H" Series



Plank Selection & Design Loads/Deflections

Allowable Loads and Deflections: U=Uniform Load (lb./ft.²) C= Concentrated Load (lb.) D=Deflection (in.)

Material Gauge	Channel Depth in. (mm)	Weight lb./lin. ft. (kg/m)	Catalog Number	Span																	
				2'-0"	2'-6"	3'-0"	3'-6"	4'-0"	4'-6"	5'-0"	5'-6"	6'-0"	6'-6"	7'-0"	7'-6"	8'-0"	9'-0"	10'-0"	11'-0"	12'-0"	
Steel 11 ga.	2" (38.1)	12.7 (18.9)	H-52011	U	930	595	413	304	232	184	149	123	104	88	76	66	58	46	38	31	26
				D	.04	.06	.08	.11	.14	.18	.22	.25	.29	.34	.39	.44	.50	.63	.76	.91	1.08
				C	1860	1488	1240	1063	930	827	744	677	620	572	531	496	465	413	372	338	310
				D	.04	.06	.09	.12	.15	.19	.24	.28	.33	.38	.44	.49	.55	.68	.81	.98	1.16
	2 1/2" (63.5)	13.1 (19.5)	H-52511	U	1409	925	626	460	352	278	225	186	157	134	115	100	88	70	57	47	39
				D	.03	.05	.07	.09	.12	.15	.17	.21	.24	.28	.31	.35	.39	.47	.55	.64	.76
				C	2820	2256	1880	1611	1410	1254	1128	1025	940	868	806	752	705	626	564	513	470
				D	.04	.06	.08	.11	.14	.18	.22	.25	.29	.34	.39	.44	.50	.63	.76	.91	1.06
	3" (76.2)	13.6 (20.2)	H-53011	U	1547	989	687	504	387	305	247	204	170	146	125	110	96	76	60	51	42
				D	.04	.06	.08	.11	.15	.18	.22	.26	.30	.34	.39	.44	.48	.58	.68	.80	.95
				C	3000	2400	2000	1715	1500	1333	1180	1091	1000	923	857	800	750	667	600	545	500
				D	.03	.05	.07	.09	.12	.15	.17	.21	.24	.28	.31	.35	.39	.47	.55	.64	.76
4" (101.6)	14.4 (21.4)	H-54011	U	2538	1624	1129	828	635	502	406	334	280	240	207	181	158	125	101	84	70	
			D	.03	.05	.07	.09	.12	.14	.17	.20	.23	.27	.31	.35	.39	.47	.56	.66	.78	
			C	4920	3936	3280	2812	2460	2187	1968	1789	1640	1514	1406	1312	1230	1094	935	895	820	
			D	.03	.04	.06	.07	.09	.11	.14	.16	.19	.22	.25	.28	.31	.38	.45	.53	.63	
Steel 10 ga.	2" (50.8)	14.4 (21.4)	H-52010	U	1034	661	459	337	258	204	165	136	116	97	84	73	65	51	42	34	29
				D	.04	.06	.08	.11	.14	.18	.22	.25	.29	.34	.39	.44	.50	.63	.76	.91	1.08
				C	2067	1653	1378	1181	1033	919	827	752	689	636	590	551	517	459	413	376	344
				D	.04	.06	.09	.12	.15	.19	.24	.28	.33	.38	.44	.49	.55	.68	.81	.98	1.16
	2 1/2" (63.5)	14.8 (22.0)	H-52510	U	1617	1034	718	528	404	319	259	214	180	153	132	115	101	81	65	54	45
				D	.05	.07	.10	.14	.18	.23	.27	.32	.36	.42	.49	.55	.62	.79	.96	1.15	1.35
				C	3133	2507	2089	1790	1567	1393	1253	1139	1044	964	895	836	783	696	627	570	522
				D	.04	.06	.08	.11	.14	.18	.22	.25	.29	.34	.39	.44	.50	.63	.76	.91	1.08
	3" (76.2)	15.4 (22.9)	H-53010	U	1720	1101	765	562	430	339	276	228	190	163	141	122	107	85	68	57	48
				D	.04	.06	.08	.11	.15	.18	.22	.26	.30	.34	.39	.44	.48	.58	.68	.80	.95
				C	3333	2667	2222	1905	1667	1481	1311	1212	1111	1026	952	889	833	741	667	606	556
				D	.03	.05	.07	.09	.11	.12	.17	.21	.24	.28	.31	.35	.39	.47	.55	.64	.76
4" (101.6)	16.4 (24.4)	H-54010	U	2821	1805	1254	921	706	557	452	373	312	268	231	201	177	139	113	93	77	
			D	.03	.05	.07	.09	.12	.14	.17	.20	.23	.27	.31	.35	.39	.47	.56	.66	.76	
			C	5467	4373	3644	3124	2733	2430	2187	1988	1822	1682	1562	1458	1367	1215	1039	994	911	
			D	.03	.04	.05	.07	.09	.11	.14	.16	.19	.22	.25	.28	.31	.38	.45	.53	.63	



Grip Strut Plank - Safe Loading Tables

5-Diamond Plank — 23¹/₄" Width — "H" Series cont.

Plank Selection & Design Loads/Deflections

Allowable Loads and Deflections: U=Uniform Load (lb./ft.²) C= Concentrated Load (lb.) D=Deflection (in.)

Material Gauge	Channel Depth in. (mm)	Weight lb./lin. ft. (kg/m)	Catalog Number	Span																	
				2'-0"	2'-6"	3'-0"	3'-6"	4'-0"	4'-6"	5'-0"	5'-6"	6'-0"	6'-6"	7'-0"	7'-6"	8'-0"	9'-0"	10'-0"	11'-0"	12'-0"	
Steel 9 ga.	2" (38.1)	16.1 (23.9)	H-52009	U	1137	727	505	371	284	224	182	150	127	107	93	81	71	56	46	38	32
				D	.04	.06	.08	.11	.14	.18	.22	.25	.29	.34	.39	.44	.50	.63	.76	.91	1.08
				C	2274	1818	1516	1299	1136	1011	910	827	758	700	649	606	569	505	454	414	378
				D	.04	.06	.09	.12	.15	.19	.24	.28	.33	.38	.44	.49	.55	.68	.81	.98	1.16
	2 ¹ / ₂ " (63.5)	16.7 (24.8)	H-52509	U	1778	1137	790	581	444	359	283	234	197	167	144	125	110	88	71	59	48
				D	.05	.07	.10	.14	.18	.23	.27	.32	.36	.42	.49	.55	.62	.79	.96	1.15	1.35
				C	3446	2758	2298	1969	1724	1532	1378	1253	1148	1060	985	920	861	766	690	627	574
				D	.04	.06	.08	.11	.14	.18	.22	.25	.29	.34	.39	.44	.50	.63	.76	.91	1.08
	3" (76.2)	17.2 (25.6)	H-53009	U	1892	1211	841	618	472	372	302	249	209	178	155	133	116	93	74	62	53
				D	.04	.06	.08	.11	.15	.18	.22	.26	.30	.34	.39	.44	.48	.58	.68	.80	.95
				C	3666	2934	2444	2096	1834	1629	1442	1333	1222	1129	1047	978	916	815	734	667	612
				D	.03	.05	.07	.09	.12	.15	.17	.21	.24	.28	.31	.35	.39	.47	.55	.64	.76
	4" (101.6)	18.3 (27.2)	H-54009	U	3103	1985	1380	1013	775	613	497	410	344	294	252	221	194	153	124	102	85
				D	.03	.05	.07	.09	.12	.14	.17	.20	.23	.27	.31	.35	.39	.47	.56	.66	.78
				C	6014	4810	4008	3436	3006	2673	2406	2187	2004	1850	1718	1604	1504	1337	1143	1093	1002
				D	.03	.04	.06	.07	.09	.11	.14	.16	.19	.22	.25	.28	.31	.38	.45	.53	.63

Strut Concentrated - Loads/Deflections⁽²⁾

Plank Width	Thickness	Concentrated C _s (lb./ft.)	
		Serrated	Non-Serrated
23 ¹ / ₄ "	11 ga. Steel	823	939
	10 ga. Steel	941	1072
	9 ga. Steel	1059	1205
	Deflection (in.)	0.08	0.07

C_s = Allowable Concentrated Load per ft. of length at mid-width (lb./ft.)
 (2) See "General Load information", page 4, for explanation of design load deflection conditions.

Strut Uniform - Loads/Deflections⁽²⁾

Plank Width	Thickness	Concentrated U (lb./ft. ²)	
		Serrated	Non-Serrated
23 ¹ / ₄ "	11 ga. Steel	850	969
	10 ga. Steel	971	1106
	9 ga. Steel	1093	1244
	Deflection (in.)	0.10	0.09

U = Allowable Uniform Load (lb./ft.²)
 (2) See "General Load information", page 4, for explanation of design load deflection conditions.