

Tubular Stringer Style - 1 1/2" (Value Line)

- Ladder type cable runway for communication cabling pathways.
- Mounts to ceilings, walls, floors, relay racks, and electronic enclosures.
- 1/2" (13mm) x 1" (25mm) steel channel welded rungs spaced 9" (228mm) on center.
- All finishes are UL Classified as suitable as an equipment grounding conductor (File number E60548). Requires the use of bonding jumpers on painted finishes to maintain classification.
- Material: ASTM A513 Grade 1008 steel tube
- Finish ___: Yellow Zinc (YZ),
Telco Gray Powder Coat (TG) or
Flat Black Powder Coat (FB)
(Other finishes are available upon request)

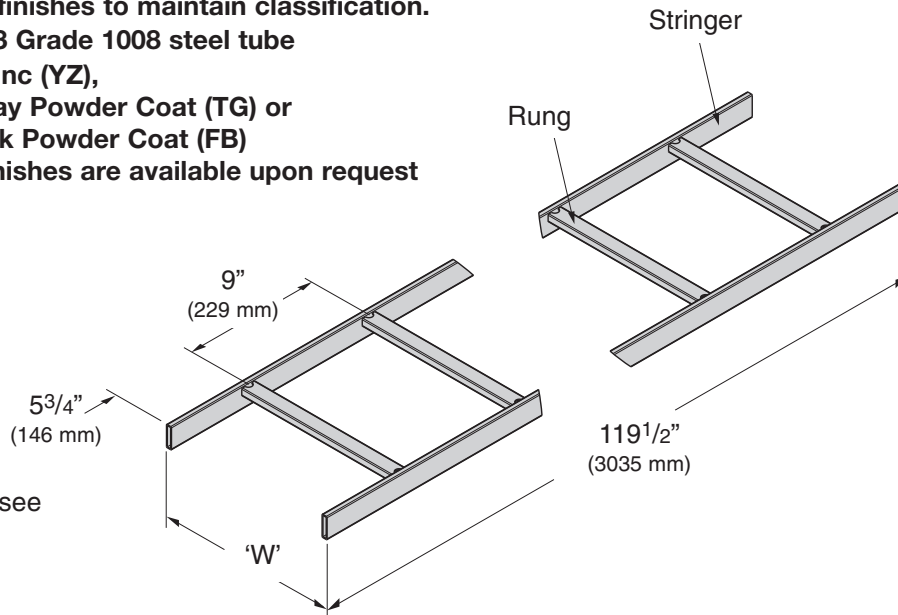

Note: For runway pans see pages 146 & 147

CABLE RUNWAYS & ACCESSORIES

Series Number	Stringer Dimensions	Span		Recommended Load		Max. Load @ 5/8" Deflection		Deflection Multiplier
		Ft.	(m)	Lbs./Ft.	(N/m)	Lbs./Ft.	(N/m)	
SB17		4	(1.22)	149	(2174)	347	(5062)	0.0018
		5	(1.52)	95	(1386)	145	(2115)	0.0043
		6	(1.83)	66	(963)	70	(1021)	0.0089

UL Cross Sectional Area
0.40 in ² (2.58 cm ²)
Design Factors for (1) Rail
Area = .210 in ² (1.35 cm ²)
Sx = .066 in ³ (1.08 cm ³)
Ix = .050 in ⁴ (2.08 cm ⁴)

SB17 Tubular - 1 1/2" (38mm) Stringers

Part Number	'W' Width		Weight	
	In.	(mm)	Lbs.	(kg)
SB1706__	6"	(152)	18.7	(8.5)
SB1709__	9"	(228)	20.9	(9.5)
SB1712__	12"	(305)	23.1	(10.5)
SB1715__	15"	(381)	25.2	(11.5)
SB1718__	18"	(457)	27.4	(12.4)
SB1720__	20"	(508)	28.8	(13.0)
SB1724__	24"	(609)	31.7	(13.4)
SB1730__	30"	(762)	36.1	(16.4)
SB1736__	36"	(914)	40.4	(18.3)

Rung Profile

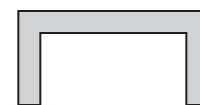

1/2" x 1"
11 gauge

FB & TG are popular Bee List items